

**PRODUCT TECHNICAL SHEET**

Collection : **1921**

Ref. : **1921.--.12**

Mélangeur cuisine 2 trous, douchette poign,e poussoir, inverseur automatique et bec mobile

2-gats keukenmengkraan, handdouche met drukknop, automatische omschakelaar en draibare uitloop

2-hole kitchen mixer, handshower with pusher, automatic diverter and swing spout

**Picture**



**Product details**

Weight : 3,4 kg

Flow at 3 bar : Restricted 9 l/min

Internal mechanism : Ceramic valve 1/4 turn

Diverter : Automatic pressure diverter

Note : Handshower hose 1,5m

**Technical drawing**

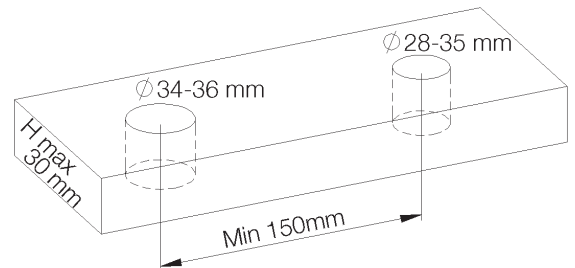
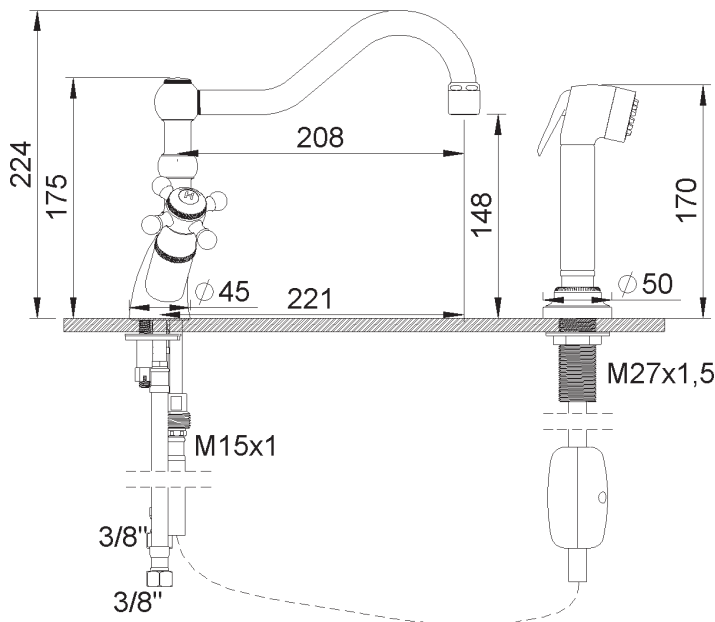

RB1.V01